

E (1 : 5)

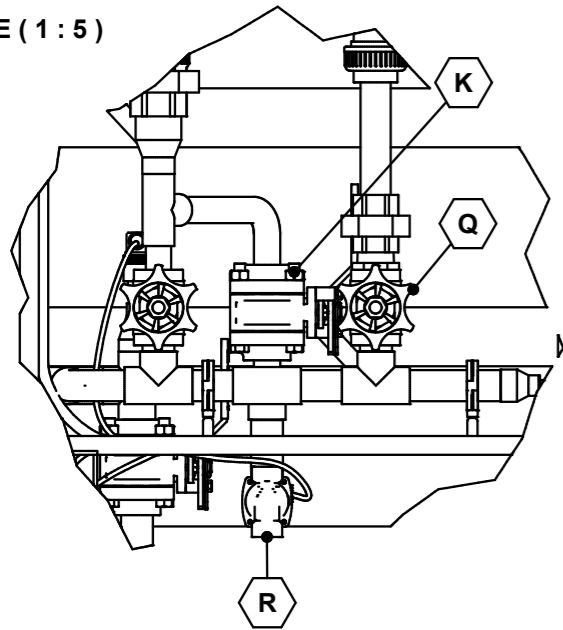

FRONT (1 : 10)

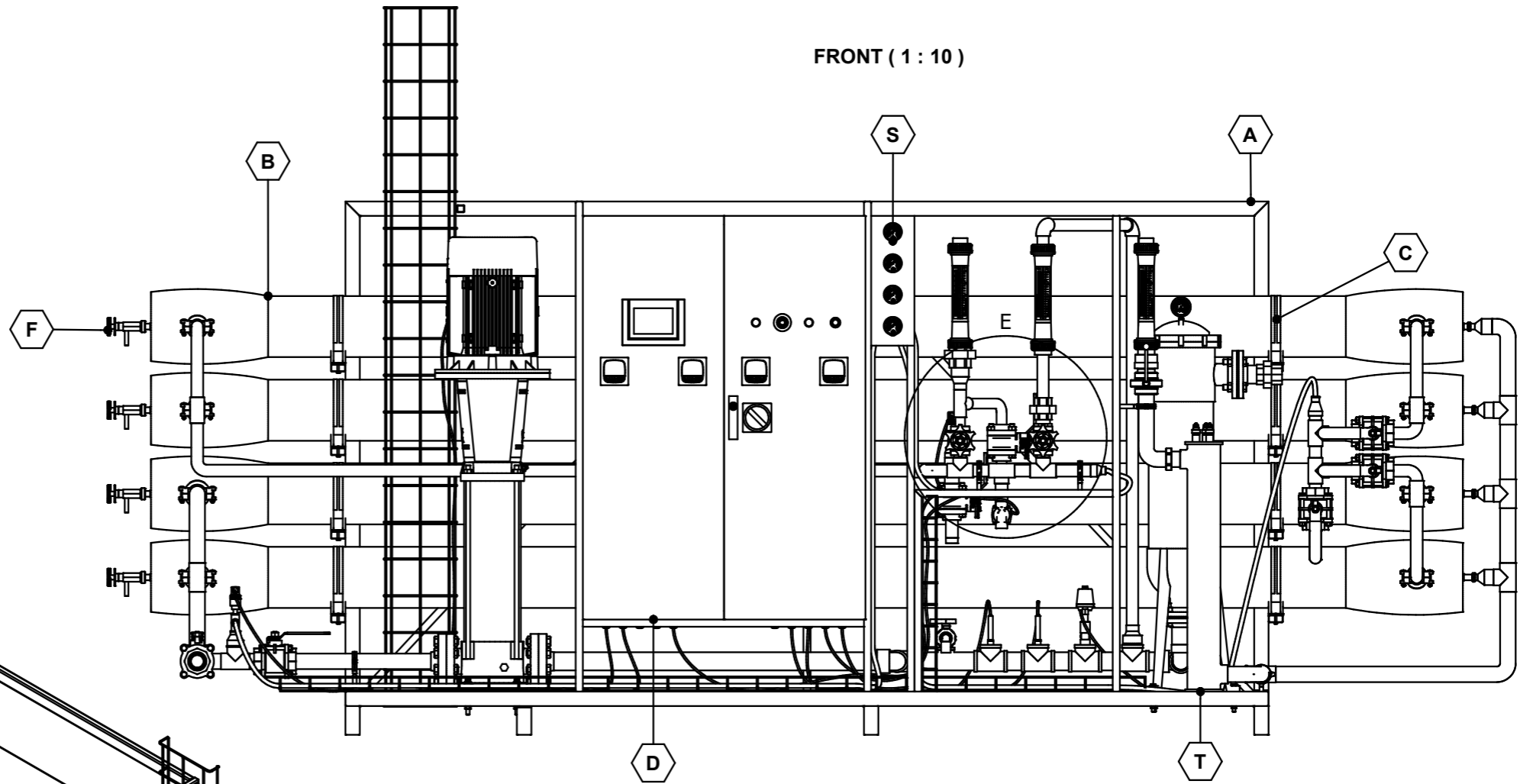

ISOMETRIC BACK (1 : 10)

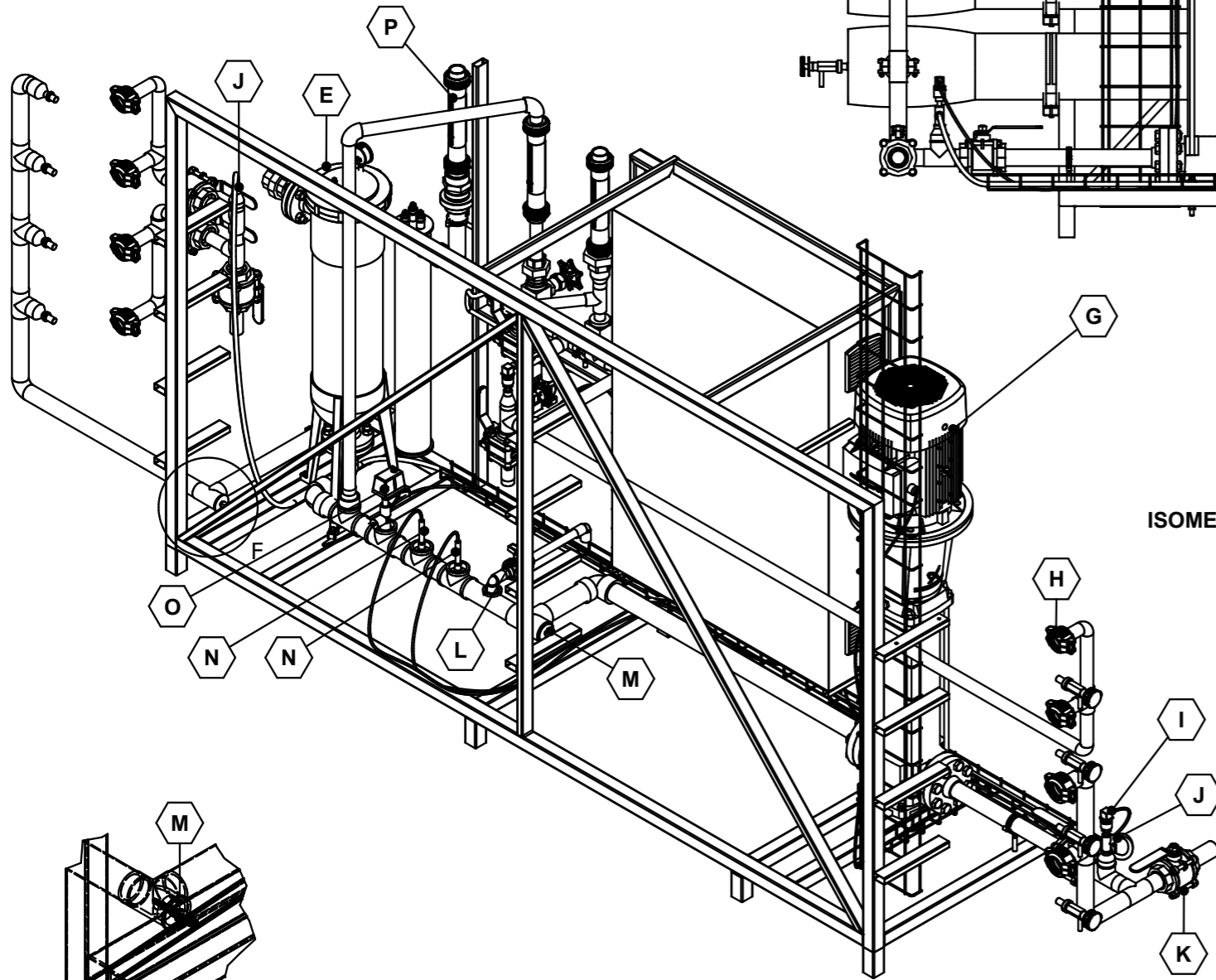

F (1 : 5)

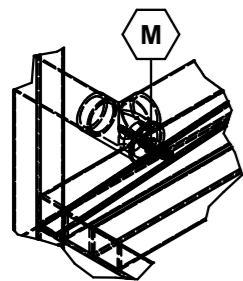

PARTS LIST	
ITEM	DESCRIPTION
A	RO Skid
B	Pressure Vessel - Codeline 80S120 -4
C	RO Strap Assembly
D	DRO Control Panel
E	PVC Bag Filter
F	Sampling Valve
G	High pressure Pump - Dayliff DIN 32 - 8
H	Victaulic Coupling
I	Pressure Transducer
J	Pressure Hose & Connector
K	SS Ball Valve
L	Feed Water Sampling Point
M	TDS Meter
N	ORP Meter
O	Pressure Switch
P	Rotameter
Q	Needle Valve
R	Solenoid Valve
S	Pressure Gauge
T	UV - SITA

Tolerance Guidelines		
Unless otherwise specified dimensions are in millimetres		
Dimension type	Normal	Datum(in bold)
Wall or section thickness	± 2.50 mm	± 0.1 mm
Length, distance, diameter	± 0.50 mm	± 0.2 mm
Angle	± 1 degree	± 0.1 degree

TITLE:

CLIENT:

JOB NO: 02

CHECKED: A.M

DATE: 10/08/2017

SIZE: A1

DRAWN: M.N.

APPROVED: D&S

REV: A

SHEET: 2 OF 2